

pag.5

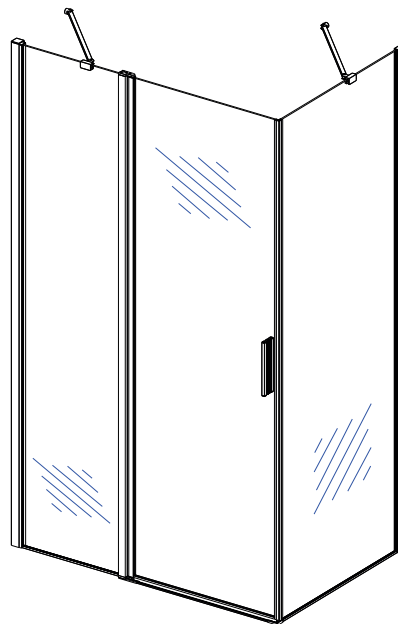

pag.15



whatsapp: +39 366 222 91 84

---

## IMPORTANTE

Prima di procedere con l'installazione del prodotto:

- controllare la compatibilità tra dimensioni della cabina e piatto doccia;
- verificare la presenza di danni dovuti al trasporto;
- verificare la perfetta planarità del piatto doccia/pavimento;
- controllare che i punti di fissaggio non coincidano con linee elettriche, gas o idriche;
- verificare che le superfici su cui dovrà essere installata la cabina siano pulite, portanti e planari.

**In caso di difformità non procedere con l'installazione e contattare tempestivamente l'azienda. Non si accettano reclami per danni su prodotti già installati.**

**Non costituiscono motivo di reclamo le perdite d'acqua causate da getti d'acqua puntati direttamente su vetri e guarnizioni.**

### INSTALLAZIONE

Viti e tasselli forniti a corredo del prodotto sono adatti per muratura in laterizio. Per l'installazione su altre pareti utilizzare fissaggi appositi. L'installazione deve essere eseguita solo da personale esperto; un montaggio non conforme alla presente istruzione invalida la garanzia.

La siliconatura della cabina doccia deve essere effettuata tassativamente all'esterno come indicato in seguito.

**La regolazione finale dei cuscinetti delle porte scorrevoli e il serraggio delle viti delle cerniere deve sempre essere verificata. La rottura del vetro della porta è spesso causata da urti dovuti ad una carente regolazione o serraggio inadeguato dei cuscinetti.**

### RACCOMANDAZIONI PER L'USO E LA MANUTENZIONE

**È assolutamente vietato dirigere il getto d'acqua a diretto contatto con i vetri e le guarnizioni.**

Asciugare sempre la cabina doccia dopo l'uso per evitare la formazione di depositi di calcare.

Per la pulizia utilizzare detergenti non aggressivi con panno morbido o spugna. Sugeriamo di impiegare una soluzione di aceto tiepido e bicarbonato.

**Evitare prodotti in pasta, candeggina, alcool, acetone, solventi e prodotti particolarmente acidi.**

Se in fase di utilizzo nel tempo il prodotto dovesse subire perdite di funzionalità (scorrimento difficoltoso, allentamento cerniere...) contattare immediatamente l'azienda per evitare danni irreparabili.

## IMPORTANT

Before proceeding with the installation of the product:

- check compatibility between cabin dimensions and shower tray;
- check for transport damage;
- check the perfect flatness of the shower / floor plate;
- check that the fixing points do not coincide with electric, gas or water lines;
- check that the surfaces on which the cabin is to be installed are clean, load-bearing and planar.

**In case of non-conformity, do not proceed with the installation and contact promptly the company. We do not accept claims for damages on products already installed.**

**Water losses caused by jets of water aimed directly on glasses and gaskets do not constitute grounds for complaint.**

### INSTALLATION

Screws and dowels supplied with the product are suitable for brick masonry. To install on other walls, use special fasteners. Installation must be performed only by expert personnel; an assembly that does not comply with this instruction will invalidate the warranty.

**The siliconization of the shower enclosure must be carried out strictly outside as indicated below.**

**The final adjustment of the sliding door bearings and the tightening of the hinge screws must always be checked. Breakage of the glass of the door is often caused by impacts due to inadequate adjustment or tightening of the bearings.**

### RECOMMENDATIONS FOR USE AND MAINTENANCE

**It is absolutely forbidden to direct the water jet in direct contact with the glasses and gaskets.**

Always dry the shower enclosure after use to avoid limescale deposits.

For cleaning, use non-aggressive detergents with a soft cloth or sponge. We suggest using a solution of warm vinegar and bicarbonate.

**Avoid products in paste, bleach, alcohol, acetone, solvents and particularly acid products.**

If during use the product should suffer loss of functionality (difficult sliding, loosening hinges ...) contact the company immediately to avoid irreparable damage.

# IMPORTANT

Avant de procéder à l'installation du produit:

- vérifier la compatibilité entre les dimensions de la cabine et le receveur de douche;
- vérifier les dommages de transport;
- vérifier la parfaite planéité de la douche / plaque de sol;
- vérifier que les points de fixation ne coïncident pas avec les conduites électriques, de gaz ou d'eau;
- vérifier que les surfaces sur lesquelles la cabine doit être installée sont propres, porteuses et planes.

**En cas de non-conformité, ne procédez pas à l'installation et contactez rapidement l'entreprise. Nous n'acceptons aucune réclamation pour dommages sur des produits déjà installés. Les pertes d'eau causées par des jets d'eau dirigés directement sur les verres et les joints ne constituent pas un motif de plainte.**

## INSTALLATION

Les vis et chevilles fournies avec le produit conviennent à la maçonnerie en brique. Pour installer sur d'autres murs, utilisez des attaches spéciales. L'installation doit être effectuée uniquement par du personnel expert; un assemblage non conforme à cette instruction invalidera la garantie.

**La silicisation de la cabine de douche doit être effectuée strictement à l'extérieur comme indiqué ci-dessous.**

**Le réglage final des roulements des portes coulissantes et le serrage des vis des charnières doivent toujours être vérifiés. La rupture de la vitre de la porte est souvent causée par des chocs dus à un réglage ou à un serrage inadéquat des roulements.**

## RECOMMANDATIONS D'UTILISATION ET DE MAINTENANCE

**Il est absolument interdit de diriger le jet d'eau en contact direct avec les verres et les joints.**

Séchez toujours la cabine de douche après utilisation pour éviter les dépôts de calcaire.

Pour le nettoyage, utilisez des détergents non agressifs avec un chiffon doux ou une éponge. Nous suggérons d'utiliser une solution de vinaigre chaud et de bicarbonate.

**Évitez les produits en pâte, eau de javel, alcool, acétone, solvants et en particulier les produits acides.**

Si en cours d'utilisation le produit devait subir une perte de fonctionnalité (glissement difficile, desserrage des charnières ...) contacter immédiatement l'entreprise pour éviter des dommages irréparables.

# WICHTIG

Bevor Sie mit der Installation des Produkts fortfahren:

- Kompatibilität zwischen Kabinenabmessungen und Duschwanne prüfen;
- auf Transportschäden prüfen;
- überprüfen Sie die perfekte Ebenheit der Dusche / Bodenplatte;
- Stellen Sie sicher, dass die Befestigungspunkte nicht mit den Strom-, Gas- oder Wasserleitungen übereinstimmen.
- Stellen Sie sicher, dass die Oberflächen, auf denen die Kabine installiert werden soll, sauber, tragfähig und eben sind.

**Bei Nichtbeachtung fahren Sie nicht mit der Installation fort und setzen Sie sich umgehend mit dem Unternehmen in Verbindung. Schadensersatzansprüche für bereits installierte Produkte sind ausgeschlossen.**

**Wasserverluste durch direkt auf Gläser und Dichtungen gerichtete Wasserstrahlen sind kein Reklamationsgrund.**

## INSTALLATION

Mitgelieferte Schrauben und Dübel sind für Mauerwerk geeignet. Verwenden Sie zur Installation an anderen Wänden spezielle Befestigungselemente. Die Installation darf nur von Fachpersonal durchgeführt werden. Eine Montage, die dieser Anleitung nicht entspricht, führt zum Erlöschen der Garantie.

**Die Silikonisierung der Duschkabine muss wie unten angegeben ausschließlich im Freien erfolgen.**

**Die endgültige Einstellung der Schiebetürlager und das Anziehen der Scharnierschrauben muss immer überprüft werden. Ein Glasbruch der Tür wird häufig durch Stöße verursacht, die auf eine unzureichende Einstellung oder ein unzureichendes Anziehen der Lager zurückzuführen sind.**

## EMPFEHLUNGEN FÜR GEBRAUCH UND WARTUNG

**Es ist absolut verboten, den Wasserstrahl in direkten Kontakt mit den Gläsern und Dichtungen zu bringen.**

Trocknen Sie die Duschkabine nach Gebrauch immer ab, um Kalkablagerungen zu vermeiden.

Verwenden Sie zur Reinigung nicht aggressive Reinigungsmittel mit einem weichen Tuch oder Schwamm. Wir empfehlen die Verwendung einer Lösung aus warmem Essig und Bicarbonat.

**Vermeiden Sie Produkte in Paste, Bleichmittel, Alkohol, Aceton, Lösungsmitteln und besonders sauren Produkten.**

Sollte das Produkt während des Gebrauchs an Funktionalität verlieren (schwieriges Gleiten, Lockern der Scharniere ...), wenden Sie sich sofort an das Unternehmen, um irreparable Schäden zu vermeiden.

## ВАЖНО

Прежде чем приступить к установке продукта:

- проверить совместимость размеров кабины и поддона;
- проверить на наличие повреждений при транспортировке;
- проверить идеальную плоскостность душевой / напольной плиты;
- убедитесь, что точки крепления не совпадают с электрическими, газовыми или водопроводными линиями;
- Проверьте, чтобы поверхности, на которых должна быть установлена кабина, были чистыми, несущими и плоскими.

**В случае несоответствия, не продолжайте установку и немедленно свяжитесь с компанией. Мы не принимаем претензии на повреждения уже установленных продуктов.**

**Потери воды, вызванные струями воды, направленными непосредственно на стекла и прокладки, не являются основанием для жалобы.**

### УСТАНОВКА

Шурупы и дюбели, поставляемые с продуктом, подходят для кирпичной кладки. Для установки на другие стены используйте специальные крепления. Установка должна выполняться только опытным персоналом; сборка, которая не соответствует этой инструкции, аннулирует гарантию.

**Силицирование душевой кабины должно выполняться строго снаружи, как указано ниже.**

**Всегда следует проверять окончательную регулировку подшипников раздвижных дверей и затяжку винтов шарниров. Поломка стекла двери часто вызвана ударами из-за неадекватной регулировки или затяжки подшипников.**

### РЕКОМЕНДАЦИИ ПО ИСПОЛЬЗОВАНИЮ И ОБСЛУЖИВАНИЮ

**Категорически запрещается направлять струю воды в непосредственном контакте с стеклами и прокладками.**

Всегда сушите душевую кабину после использования, чтобы избежать отложений накипи.

Для чистки используйте неагрессивные моющие средства с мягкой тканью или губкой. Мы предлагаем использовать раствор теплого уксуса и бикарбоната.

**Избегайте продуктов в пасте, отбеливателе, спирте, ацетоне, растворителях и особенно кислотных продуктах.**

Если во время использования изделие потеряет функциональность (затрудненное скольжение, ослабление петель ...), немедленно свяжитесь с компанией, чтобы избежать непоправимого повреждения.

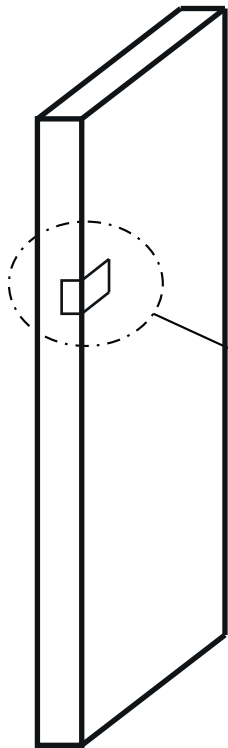

**MIN - MAX**

0101011332  
**XXXXXXXXXXXX A 77-79 ARG SAT PIUM**  
FIX (Fisso) DOOR (Porta)  
XXXXXXXXXXXX  
Ns: xxxxx  
Vs: xxxxxxx  
OP:xxxx

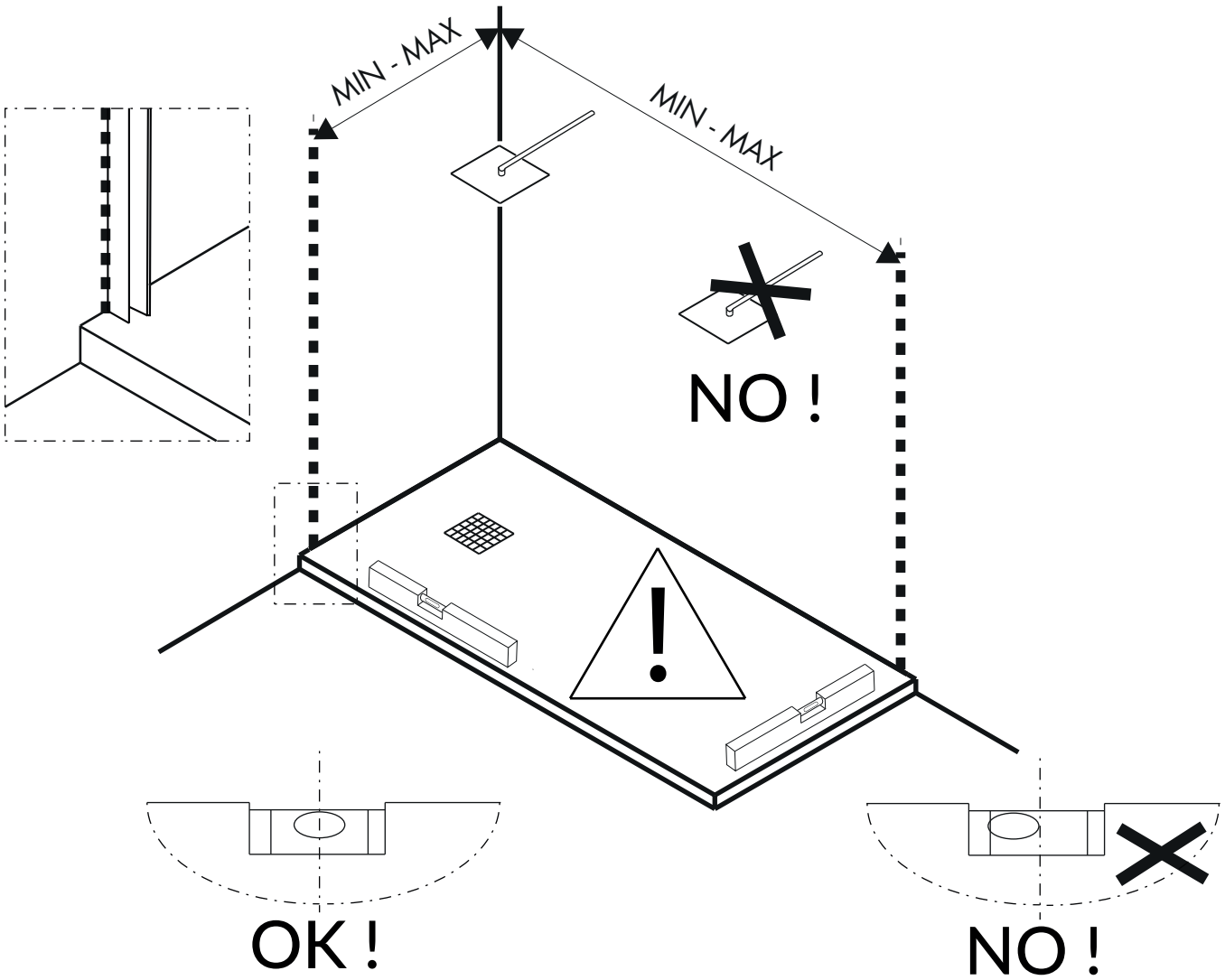

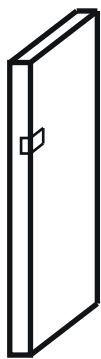

V1\_N°6pz 3,9x32

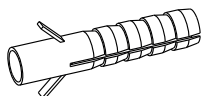

V2\_N°6pz

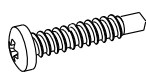

V3\_N°6pz



T1\_N°6pz

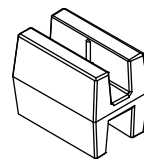

S1

T2

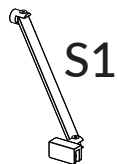

II

C1

F1

P1

G2

T2

M1

B1

C1

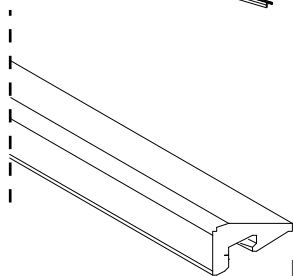

D2

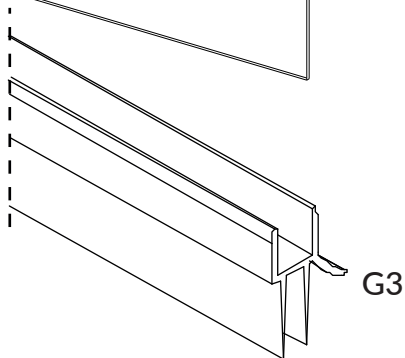

G3

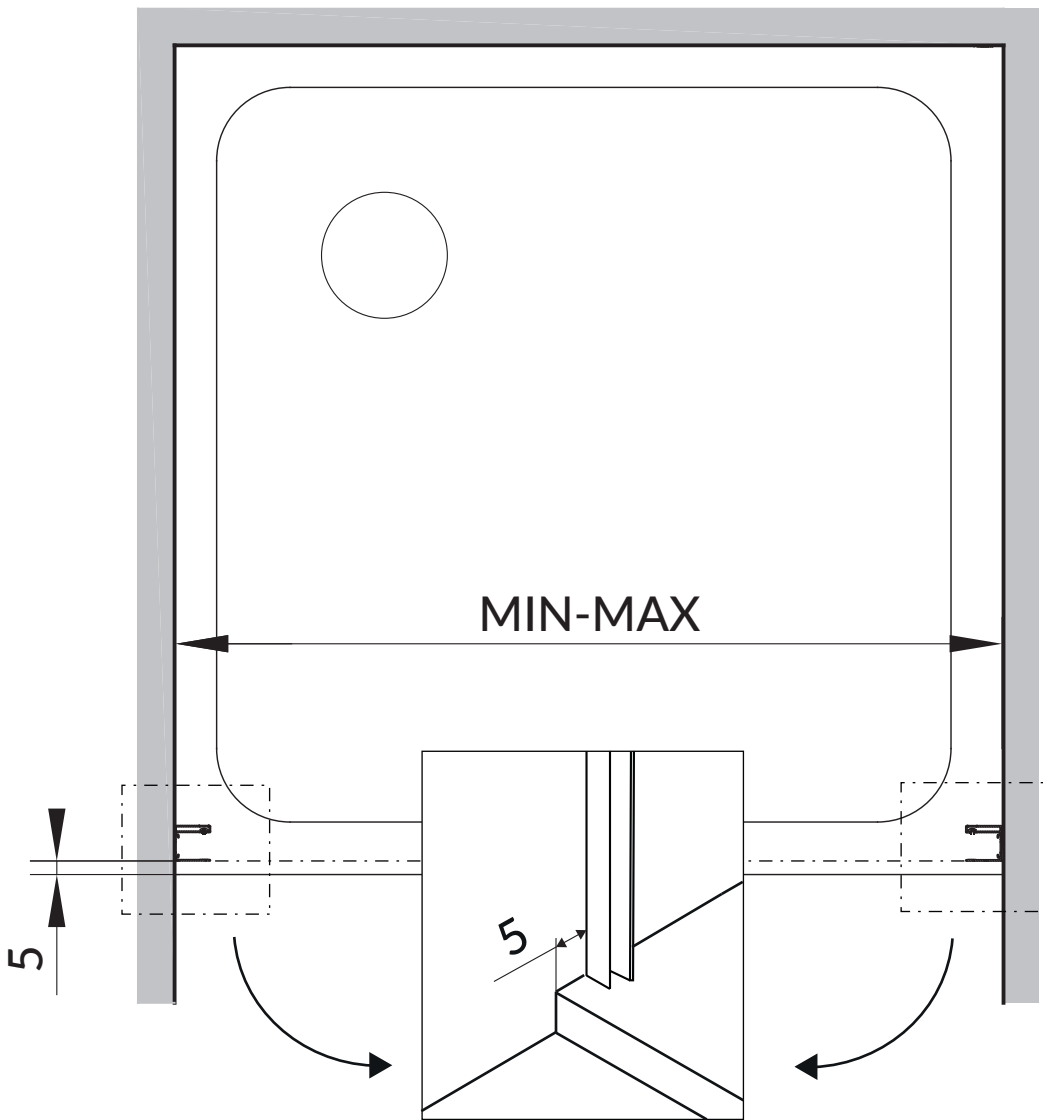
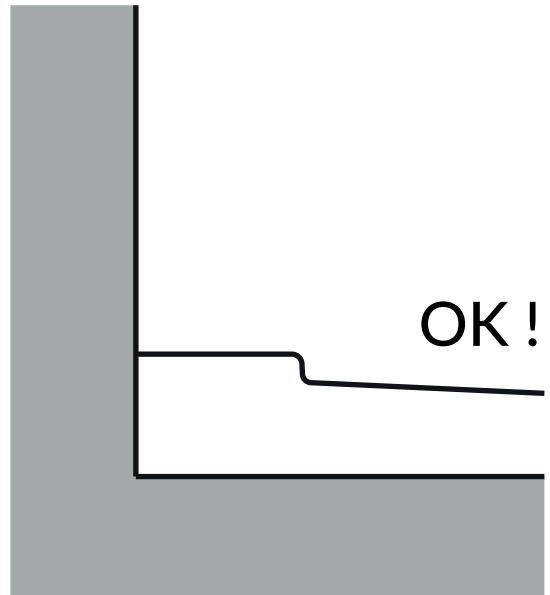
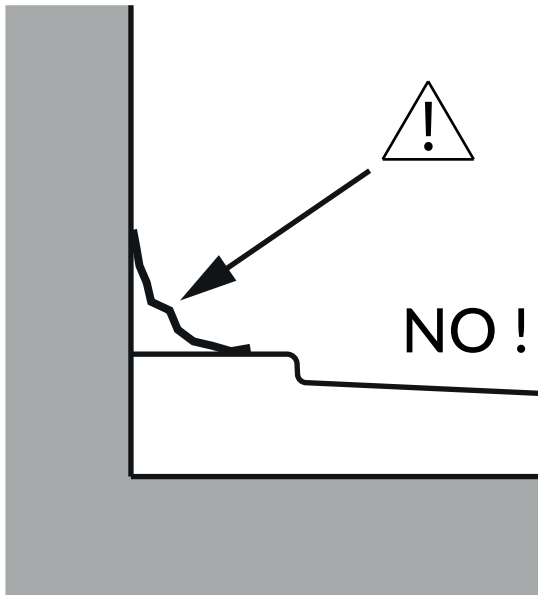

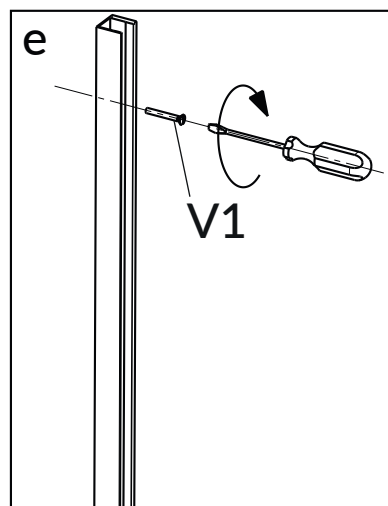
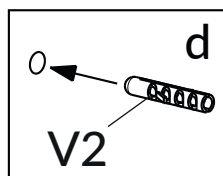
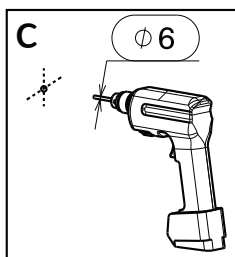
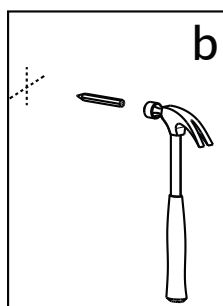
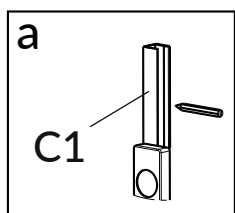
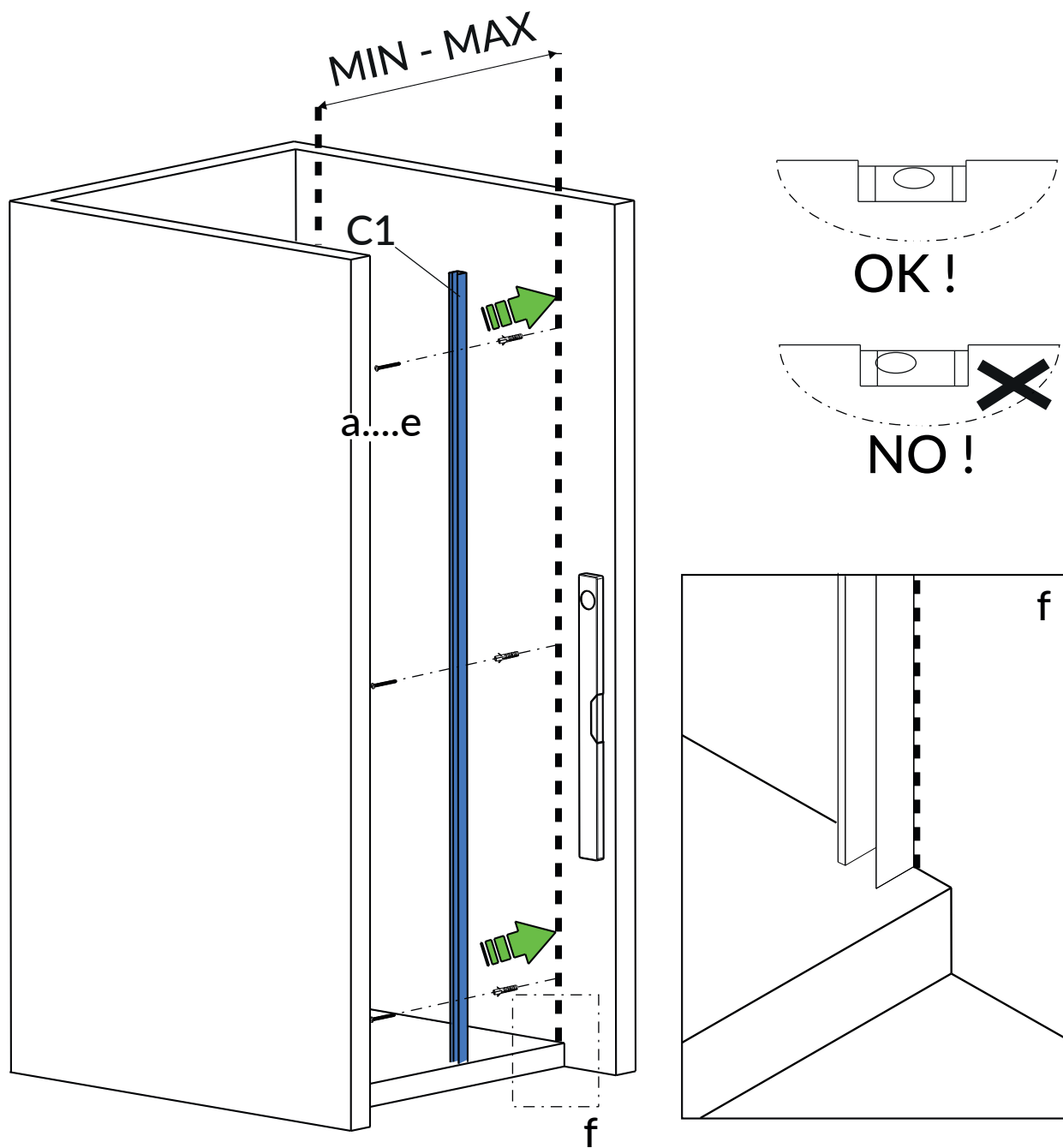



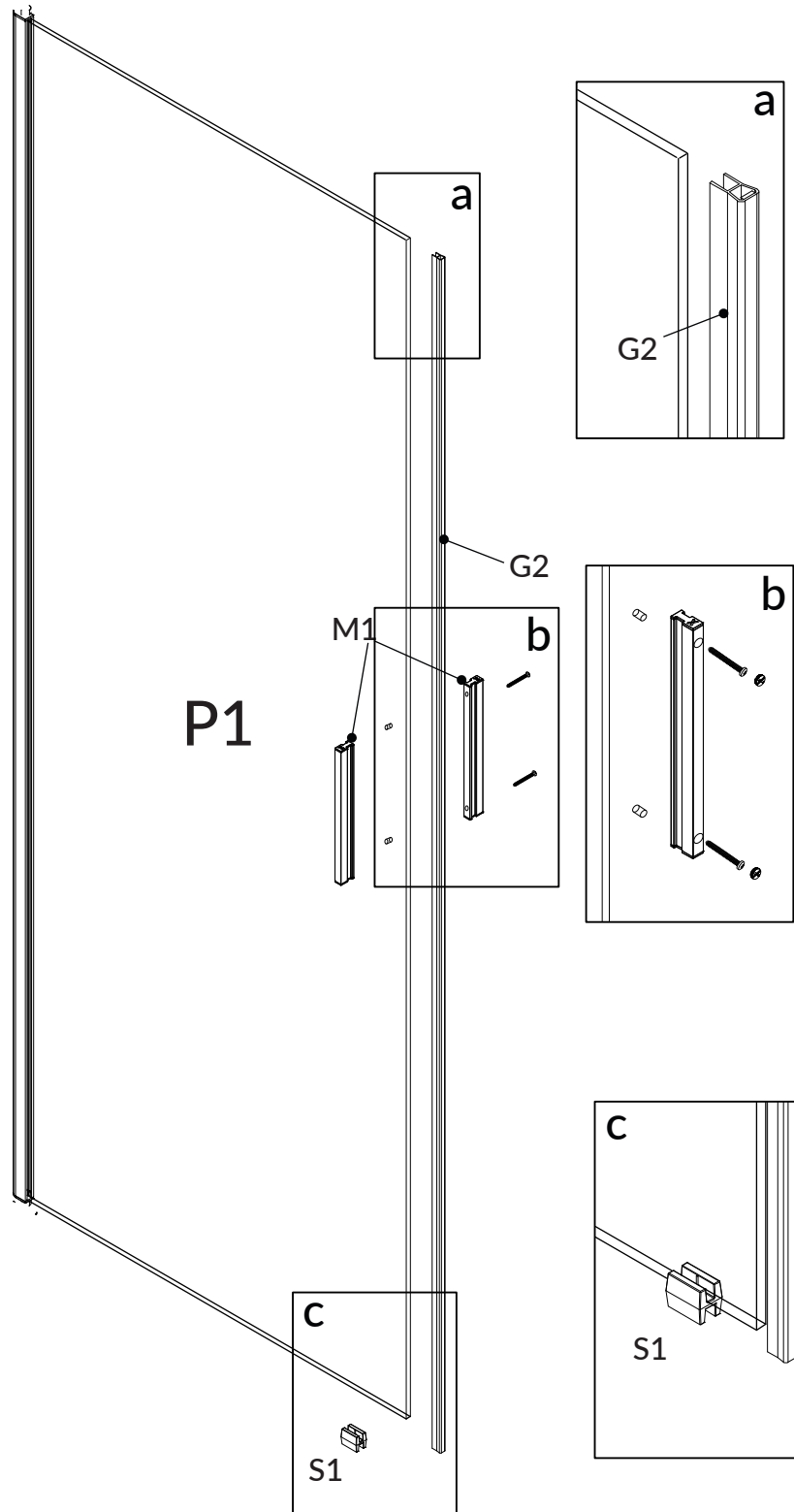

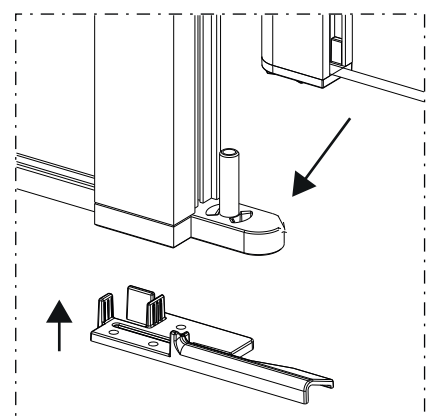
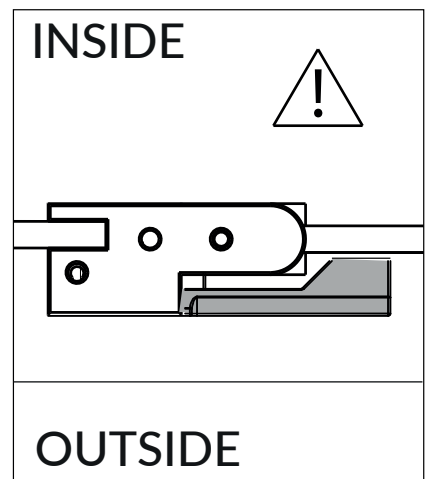
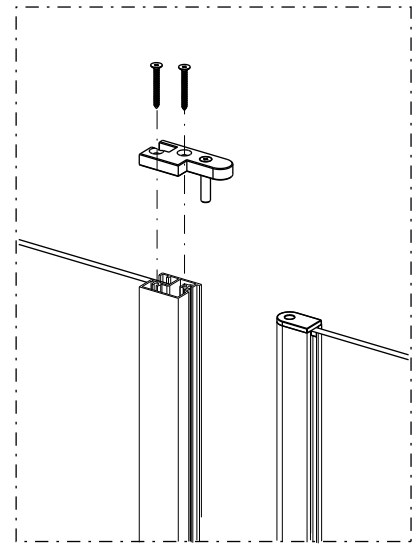
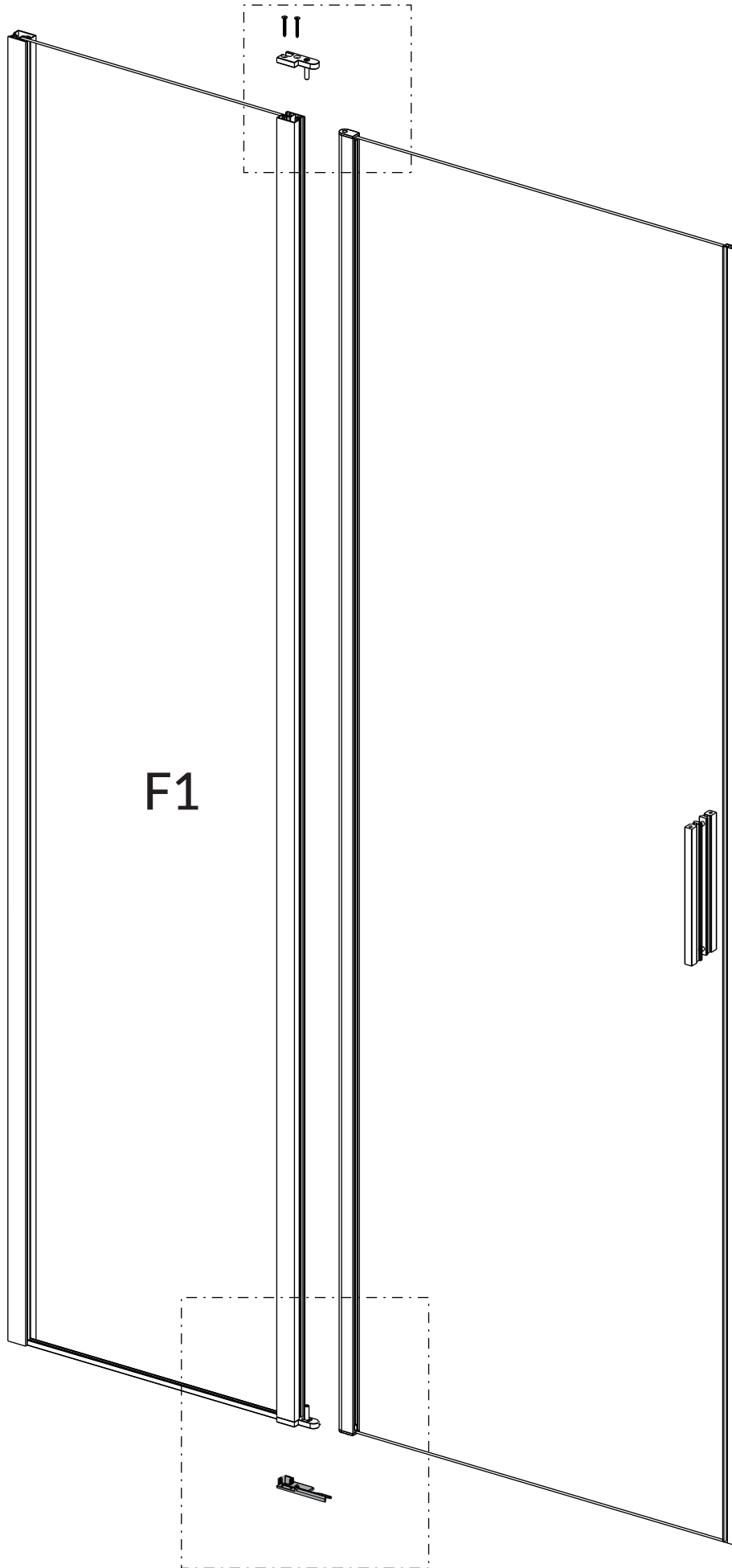

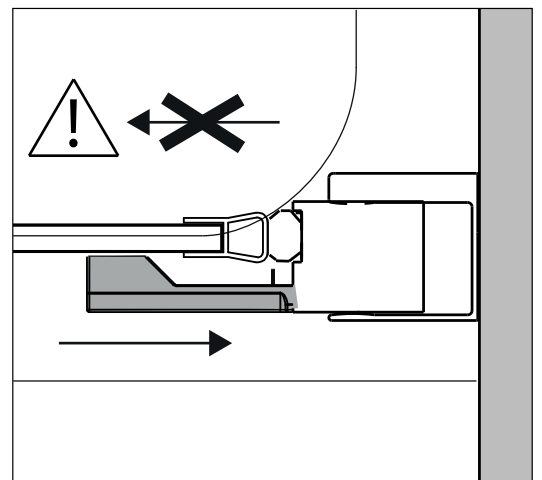
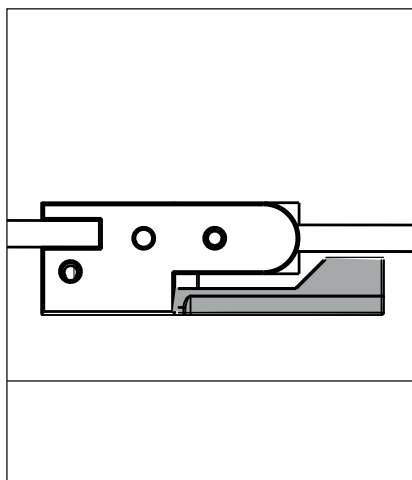
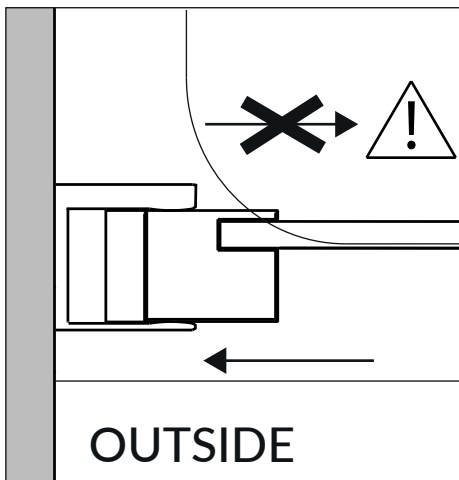
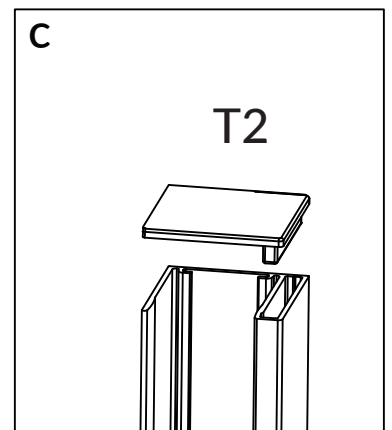
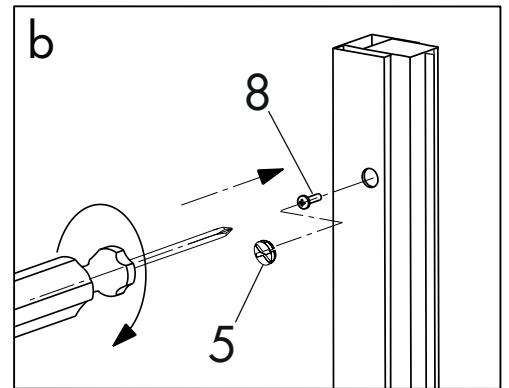
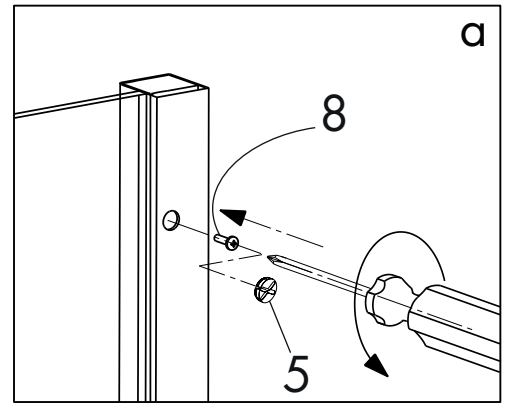
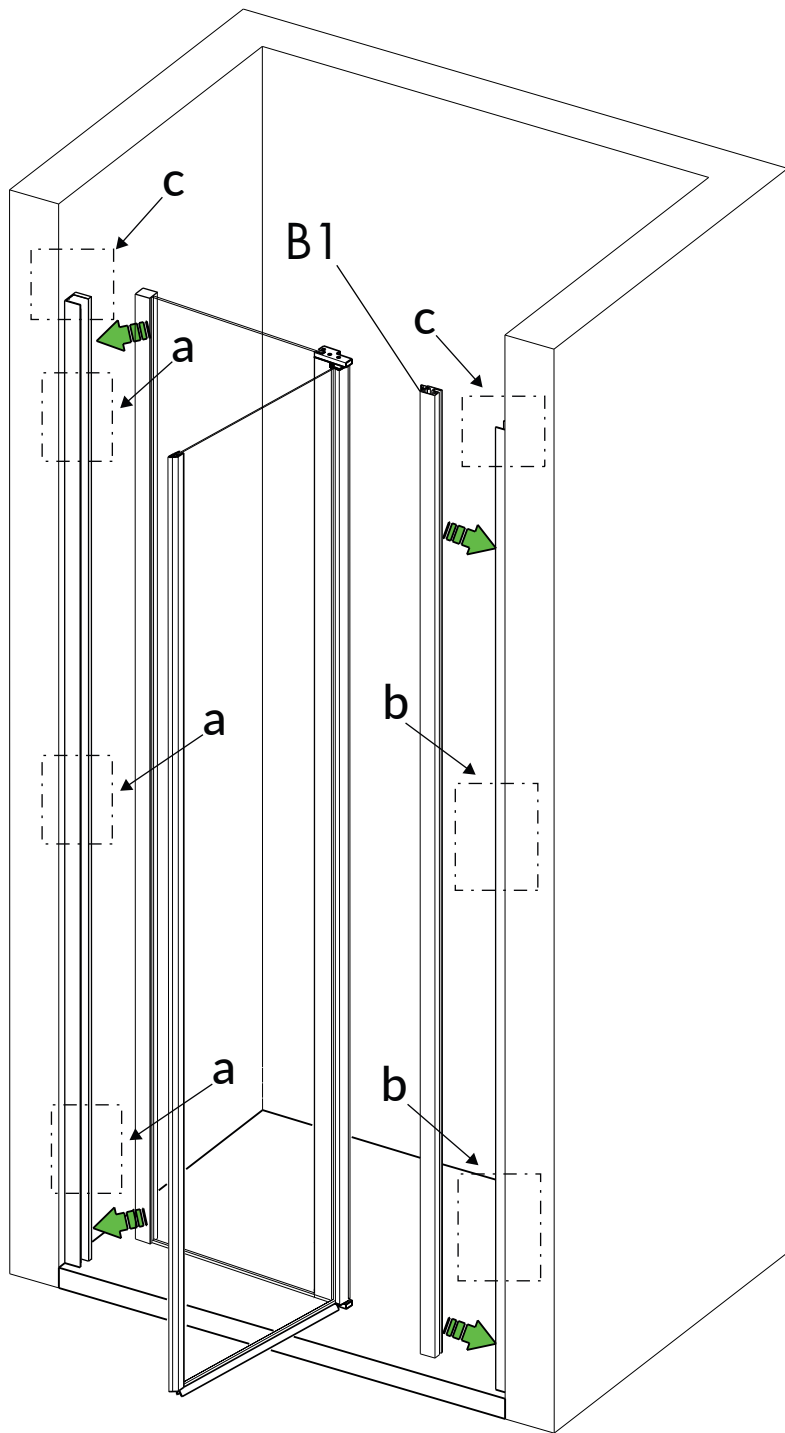

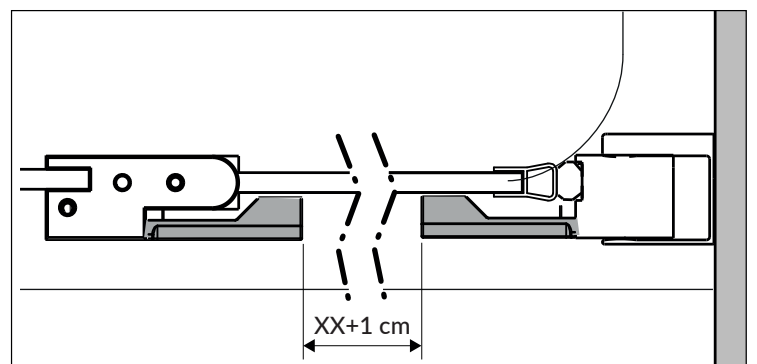
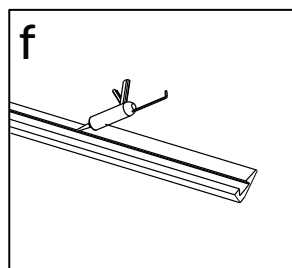
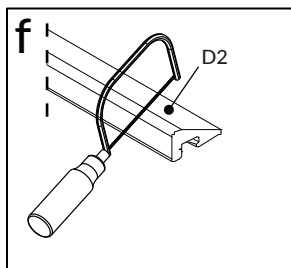
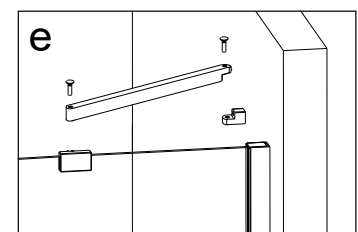
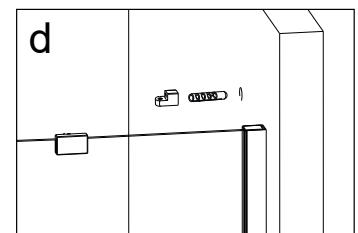
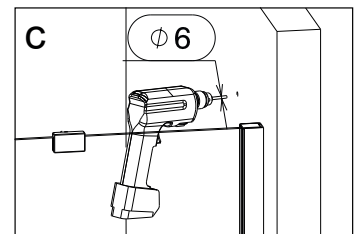
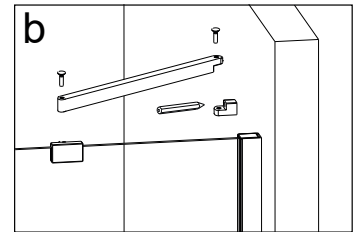
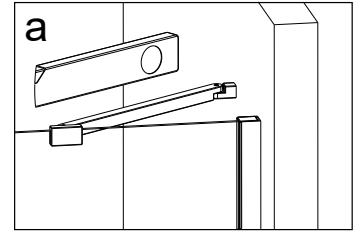
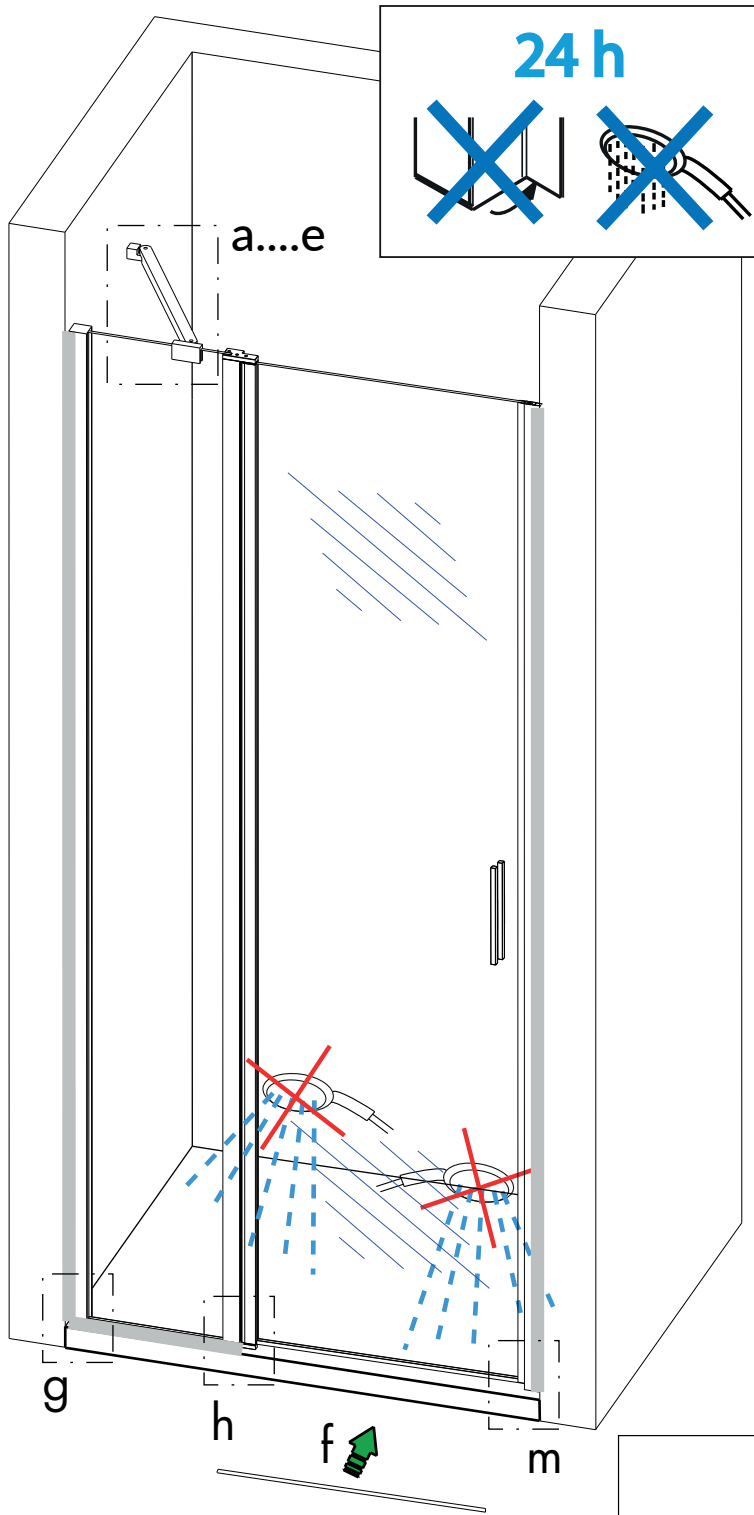
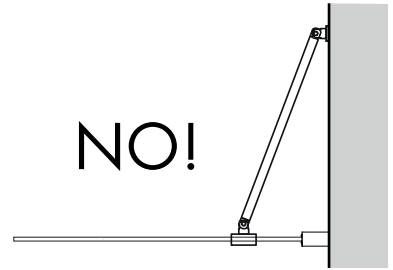
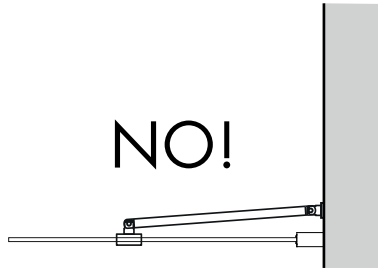
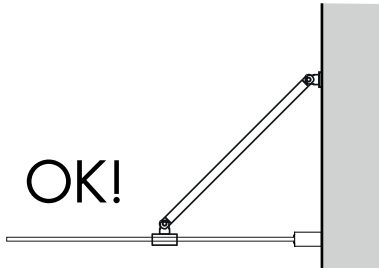

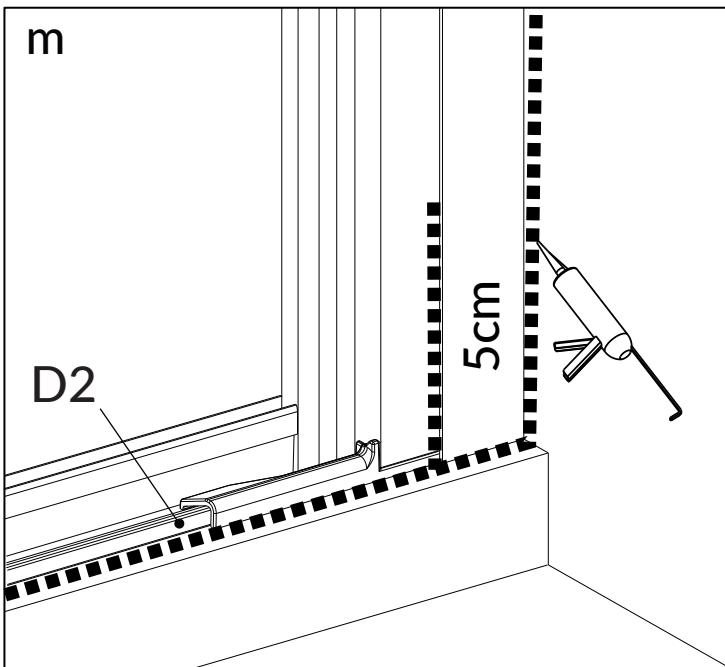
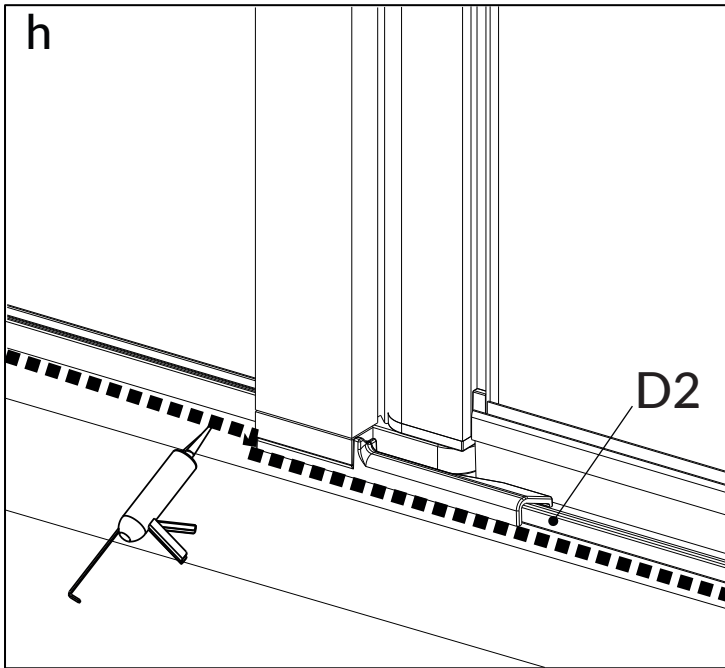
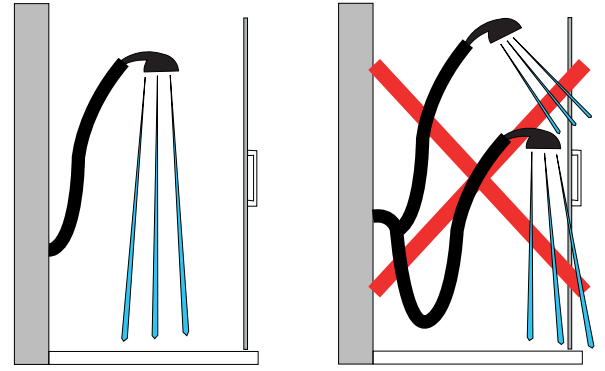
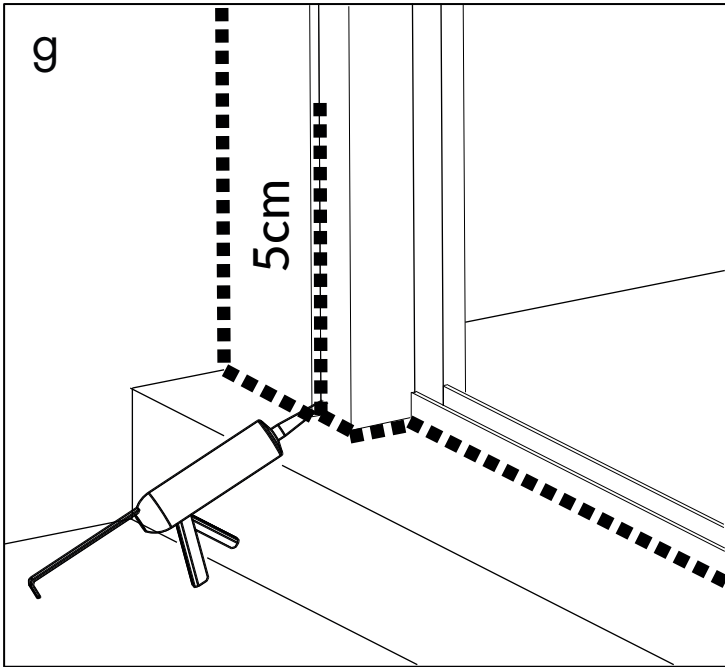



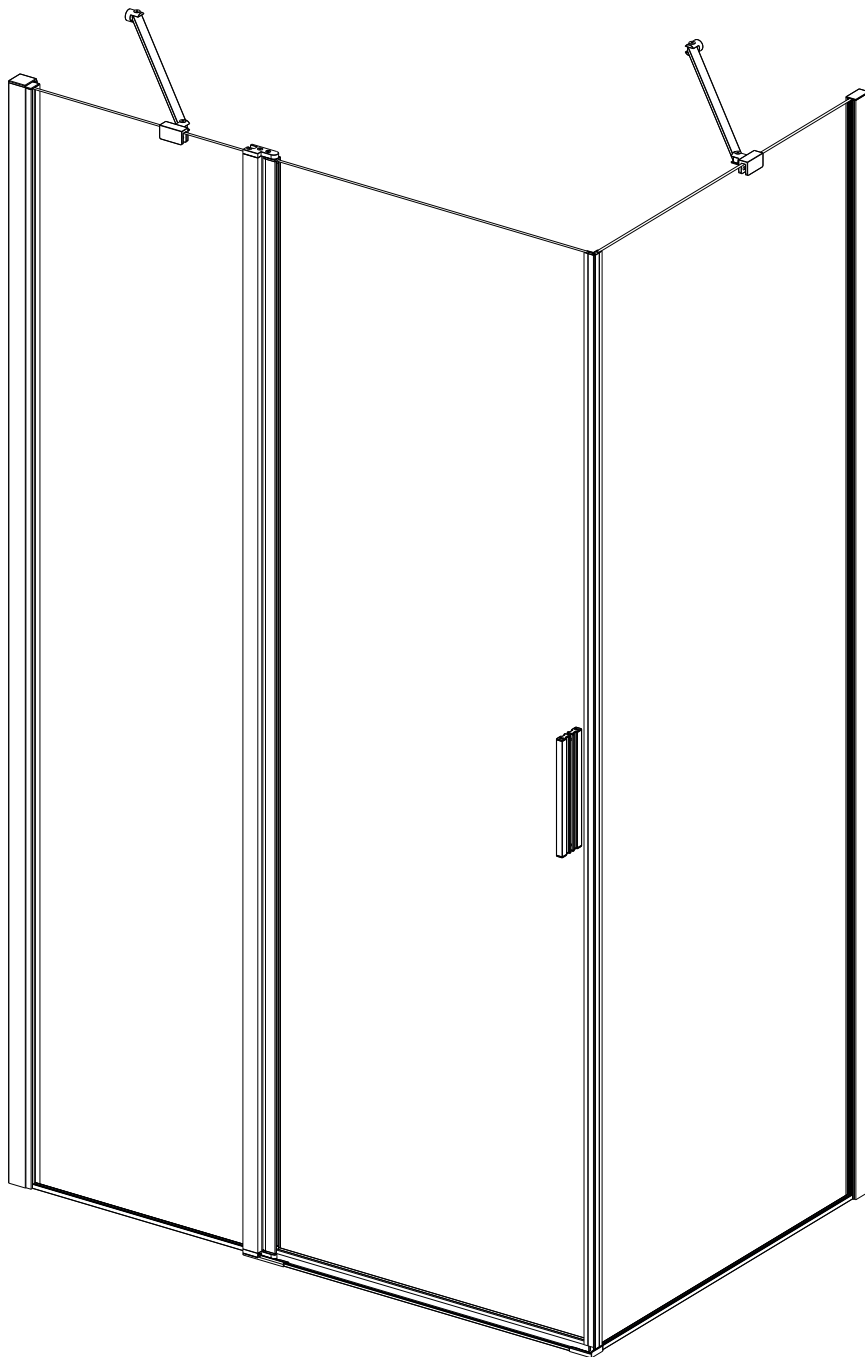
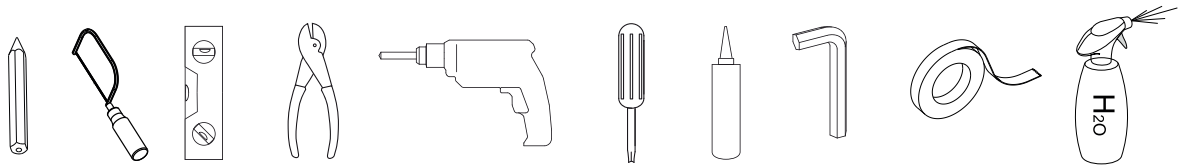

whatsapp: +39 366 222 91 84

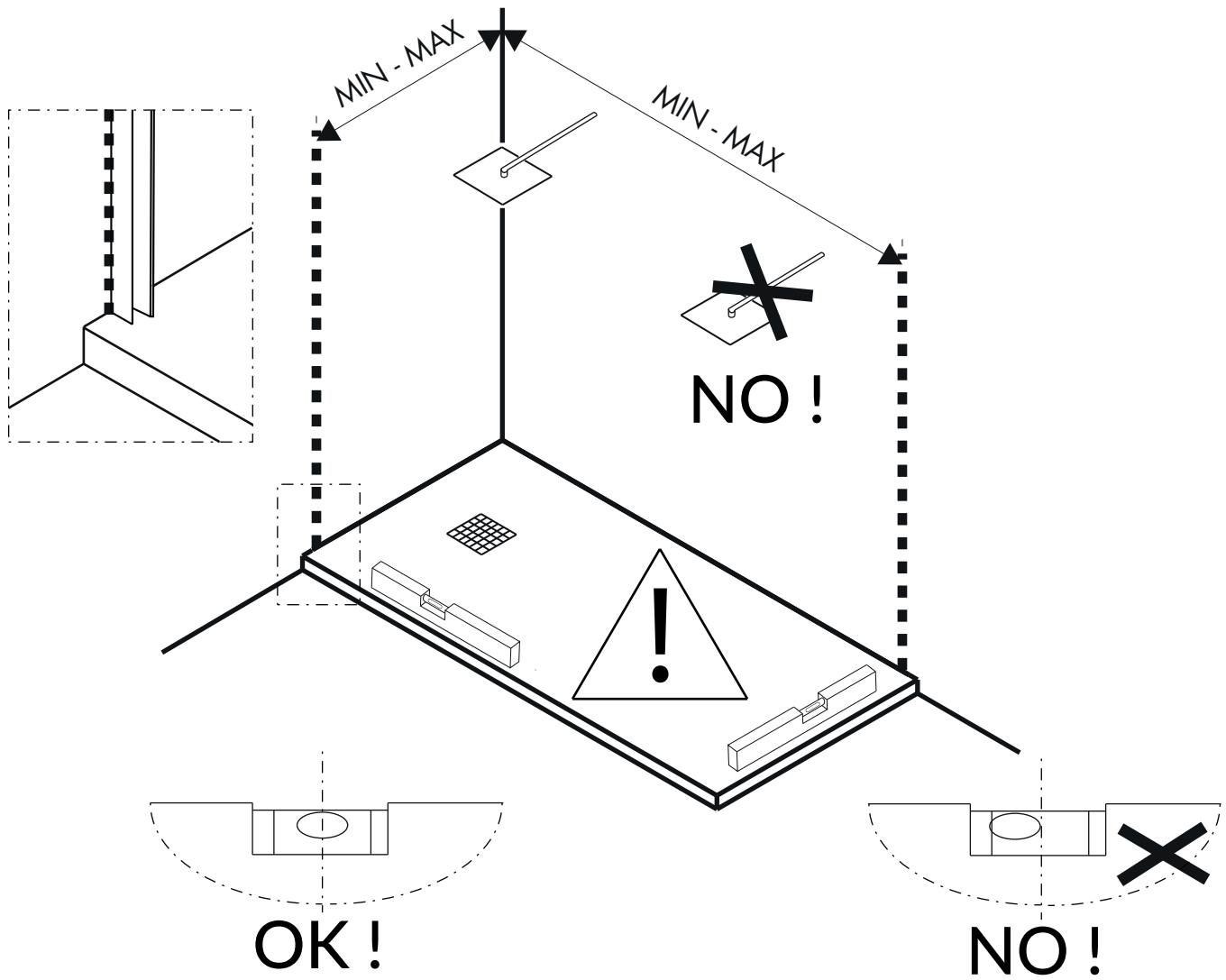
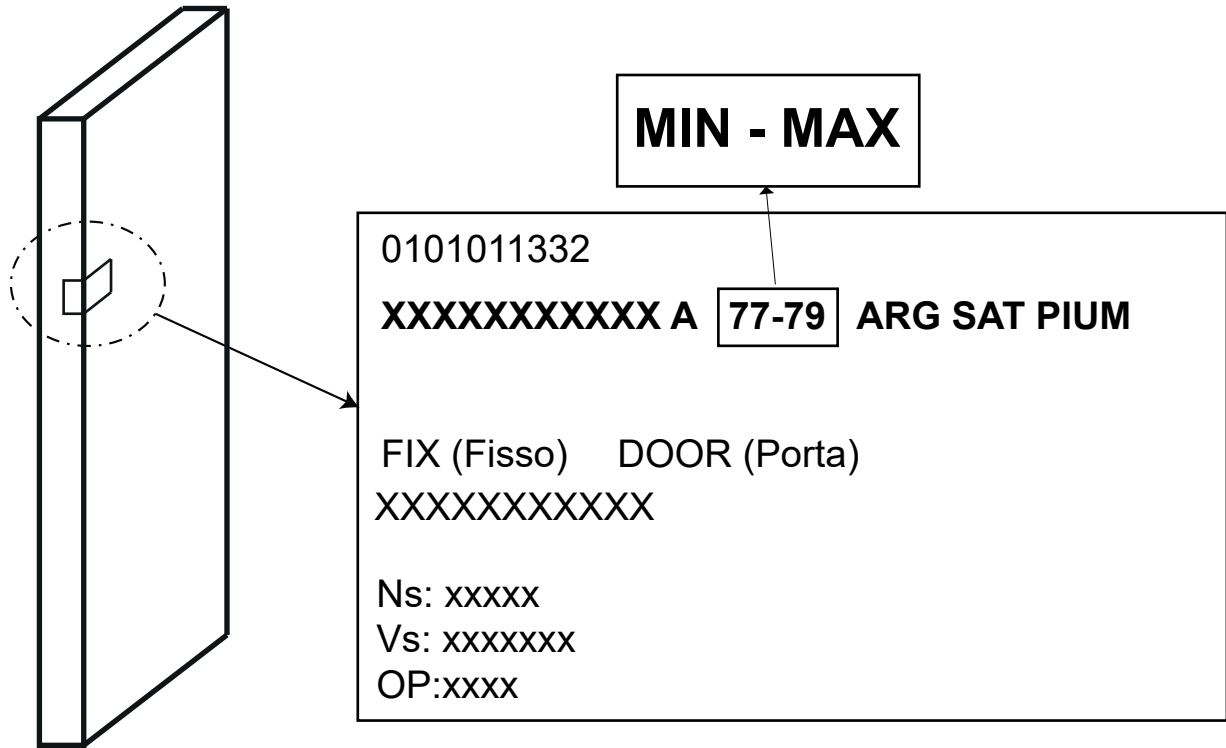



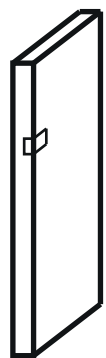

V1\_N°3pz 3,9x32

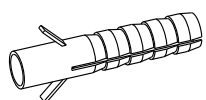

V2\_N°3pz

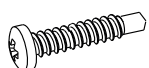

V3\_N°3pz



T1\_N°6pz

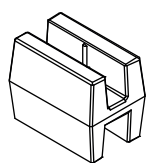

S1

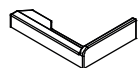

D1\_sx

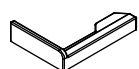

D1\_dx

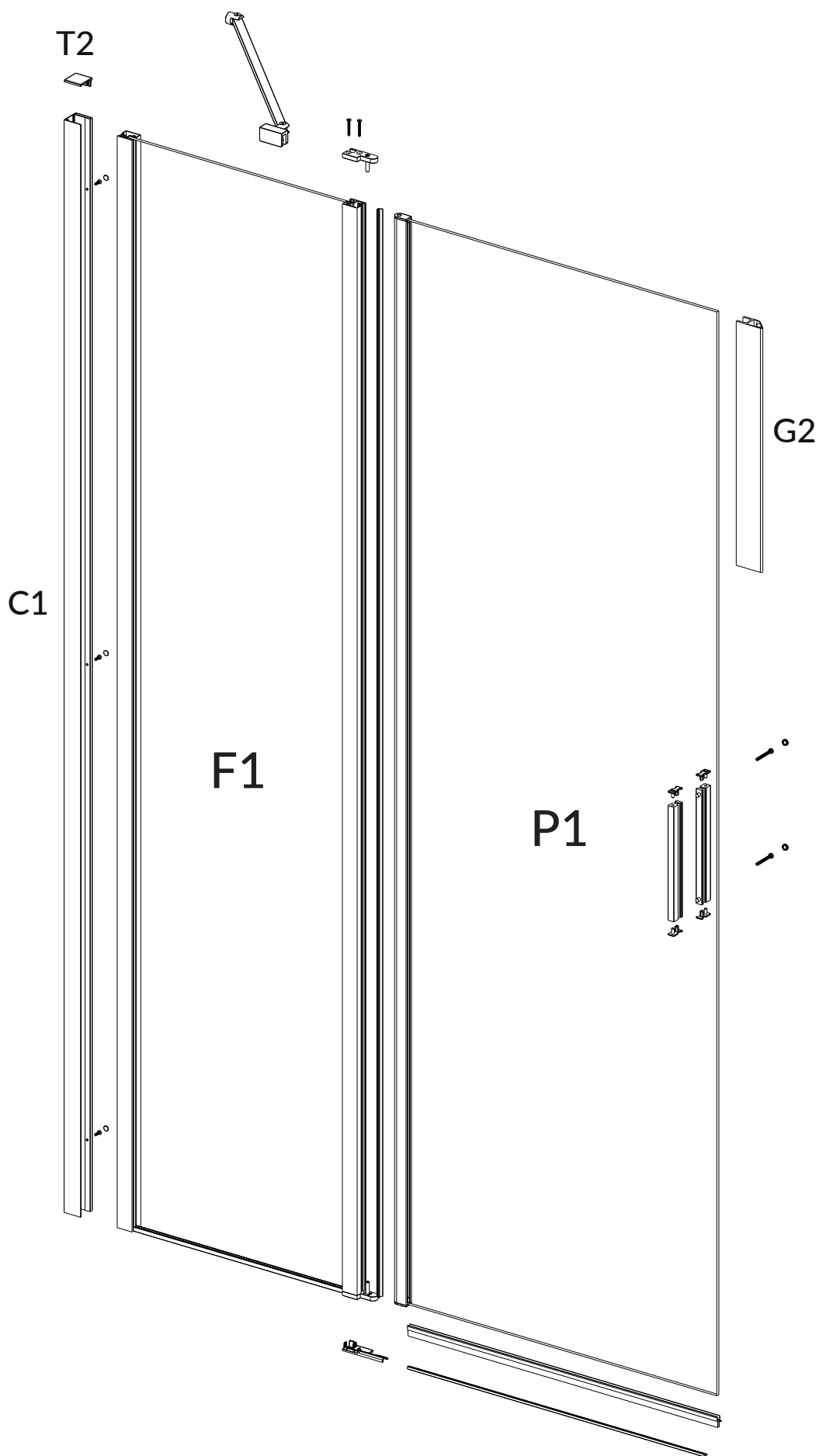

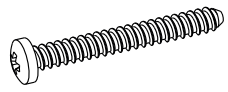

V1\_N°3pz 3,9x32

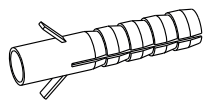

V2\_N°3pz

G2

F2

